



MEASURE YOUR STORM DRAIN

(Square/Rectangular Grated Inlets)

THE FOLLOWING MEASUREMENTS ARE REQUIRED TO PLACE AN ORDER

Please provide photos and accurate measurements with 1/8" to ensure proper installation. Submittal of this form represents that you acknowledge that all details provided are accurate, and that any issues resulting from inaccurate information herein are your responsibility. All sales of custom items are final.

CONTACT INFORMATION

Company:	Date:
Job Name:	
Job Site Address:	City/State/Zip:
Contact Name:	
Email:	Phone:

INLET, FRAME & GRATE INFORMATION

Inlet Type (e.g., WSDOT type 1):	Grate MFG/Model (e.g., Neenah R2014):
Frame Model #:	Grate Type:

STEP 1: Grate

A _____
Grate width, outside

B _____
Grate length, outside

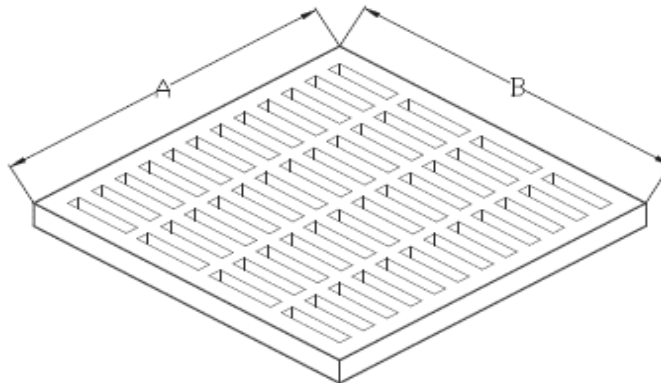

STEP 2: Grate Detail

Grate type
(pick one):

Flat



Square Belly

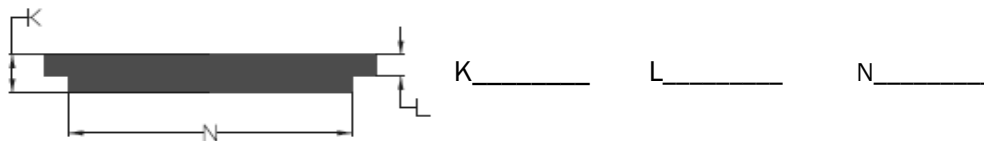

Round Belly

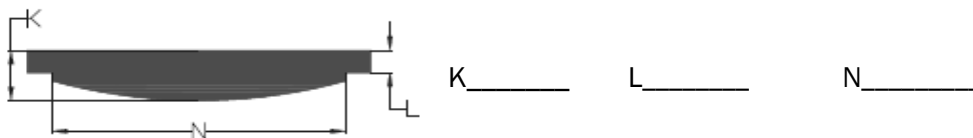

PLEASE PROVIDE SIDE VIEW PICTURES OF THE GRATE(S)



MEASURE YOUR STORM DRAIN

(Square/Rectangular Grated Inlets)

STEP 3: Storm Drain

C _____
Inside frame width or wall to wall inside the basin, whichever is less

D _____
Inside frame length or wall to wall inside the basin, whichever is less

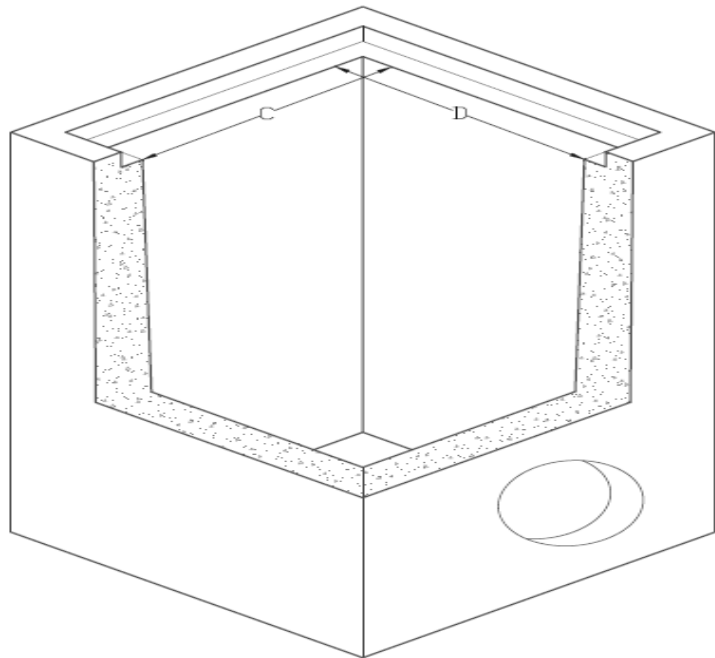

STEP 4: Storm Drain Section

E _____
Sump depth

F _____
Clearance to outlet pipe/baffle

G _____
Top of outlet to grate frame

H _____
Grate frame height

J _____
Grate frame width

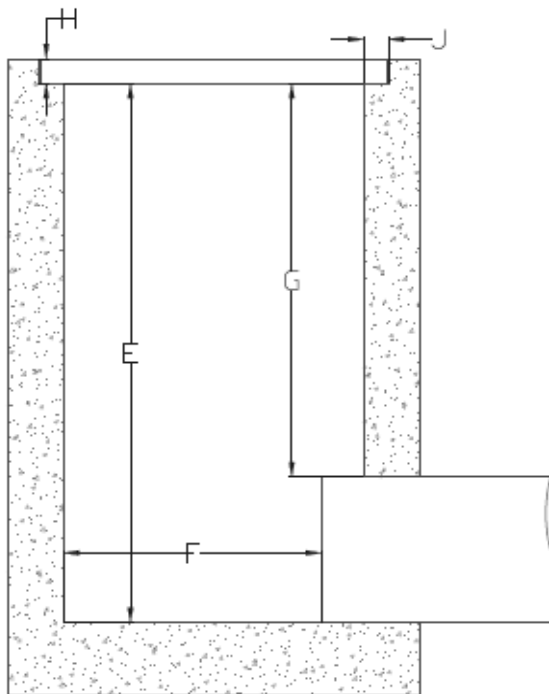

STEP 5: Inlet Pipes

Any inlet pipes? Y / N If yes, bottom of grate to top of pipe _____ Inside diameter of pipe _____

How far pipe protrudes into basin _____ Need to be filtered? Y / N

*** Please indicate location of pipe in picture above ***